



FLP-TR VX

Ex db I/IIC, Ex eb I/IIC, Ex ta IIIC, Ex nR IIC

VORTEX BARRIER GLAND for Unfilled Unarmoured Cable

Features and Benefits

- For Group I underground mines, Group II, III, Zone 1, 2, 21 and 22 hazardous areas.
- For unfilled hygroscopic multicore cables refer to IEC 60079-14; 9.3.2 and 10.6.2a, IEC 61892-7, 10.6 and 10.7.
- Fitted with specially formulated captive elastomeric seal provides Built-in Safety™.
- Provided with an extra gripper seal to grip the cable.
- Instantly mixed and injected Resin forms a 100% barrier seal around the individual cores of the cable.
- Prevents explosive gases and/or liquids transmitting down the cable.
- Precision manufactured from high-quality brass (Marine Grade Electroless Nickel Plated™) available in stainless steel 316/316L on request.
- Supplied with a thread sealing gasket (parallel threads only).



Technical Data

Type:	FLP-TR VX (VORTEX®)
Gland Material:	Brass (Marine Grade Electroless Nickel Plated™), Stainless Steel 316/316L
Seal Material:	Standard Thermoset Elastomer or Extreme Temperature Seals, Quick setting Barrier Resin
Sealing Gasket Material:	HDPE, Nylon 66 or PTFE
Cable Type:	Unarmoured
Sealing Area:	Outer sheath and QuickStop® Resin around Cable Conductors
Optional Accessories:	Adaptor, Reducer and Shroud
Note:	The installer should ensure that the materials are suitable for the installation environment.

Standards and Certifications

Equipment Protection Levels:	IECEX/INMETRO: Ex d I Mb/ IIC Gb, Ex e I Mb/IIC Gb, Ex nR IIC Gc, Ex ta IIIC Da ATEX/UKEX: Ex I M2, Ex II 2/3G 1D, Ex db I Mb/ IIC Gb, Ex eb I Mb/IIC Gb, Ex nR IIC Gc, Ex ta IIIC Da TR CU: Ex d IIC Gb X / PB Ex d I Mb X / 1Ex e IIC Gb X / ПП Ex e I Mc X / 2Ex nR IIC Gc X / Ex tb IIIC Db X	
Continuous Operating Temp:	-50°C to +95°C	
Conformance:	Standards:	Certificate:
IEC/BS EN	IEC/BS EN 62444	CML 14CA364
IECEX	IEC 60079 Part 0, 1, 7, 15, 31	IECEX TSA 22.0011X
ATEX	EN 60079 Part 0, 1, 7, 31	CML 16ATEX1001X
	EN 60079 Part 0, 15	CML 16ATEX4002X
UKEX	BS EN 60079 Part 0, 1, 7, 31	CML 21UKEX1011X
	BS EN 60079 Part 0, 15	CML 21UKEX4006X
INMETRO (Brazil)	ABNT NBR IEC 60079 Part 0, 1, 7, 15, 31	TÜV 15.0483X
TR CU (Russia)	ГОСТ 31610-0, 15, ГОСТ IEC 60079-1	EAЭC RU C-ZA.HA91.B.00245/21
	ГОСТ P MЭK 60079-7, 31	
SANS	SANS/IEC 60079 Part 0, 1, 7, 15, 31	MASC MS/22-9001X
	SANS 808	
IP66/68 - Parallel	SANS/IEC 60529	MASC MS/22-9001X
IP65 - Tapered		
IP68 - Tapered and approved grease	IEC 60529	IECEX CML 18.0018X
Deluge Protection	DTS-01	CML 14CA370-2
Corrosion Protection	ASTM B117-11, BS EN ISO 3231	EXOVA N968667
Marine ABS	IEC 60079 Part 0, 1, 7, 15, 31, IEC 60529	ABS 20-1952706-1-PDA
DNV-GL	IEC 60079 Part 0, 1, 7, IEC 60529	DNV-GL TAE0000010
EMC Compatible	EN 55011, + A1, EN 55022	SGS EMC305079/1

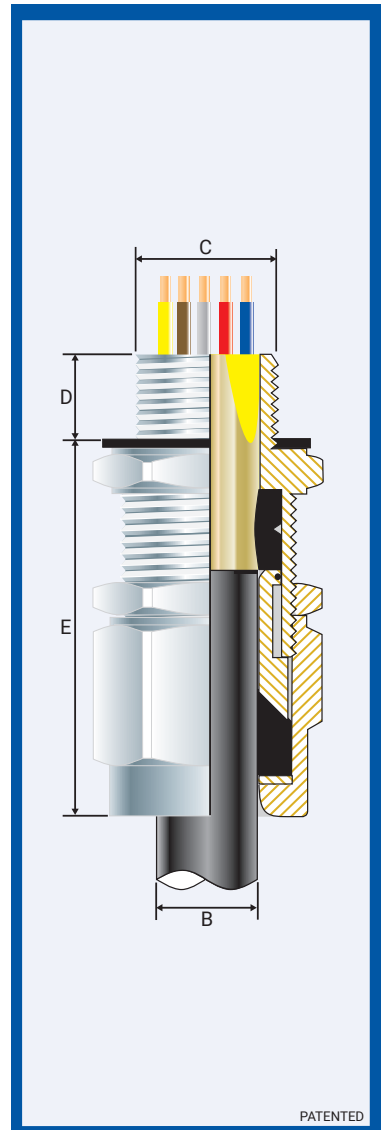

Conditions for Safe Use - X

- The cable glands shall only be used where the temperature, at the point of entry, is between -50°C to +95°C.
- Only Resin supplied by CCG may be used in the glands.

Product Code	Gland Size Reference	Metric Entry Thread		NPT Entry Thread		Cable Detail		Maximum Length 'E'	Max Dia. Over Cores	Max No. of Cores	Hexagonal Detail		Installation Torque Value Nm
		'C'	Min 'D'	'C'	Min 'D'	Min 'B'	Max 'B'				Max 'Flats'	Max 'Crns'	
058300-16-VX	00-16ss	M16x1.5	15	-	-	3.0	8.0	46.0	8.0	6	25.0	28.0	32.5
058300-VX	00-20ss	M20x1.5	15	1/2 3/4	15	3.0	8.0	46.0	10.9	10	25.0	28.0	32.5
05830-VX	0-20s	M20x1.5	15	1/2 3/4	15	8.0	11.5	46.0	10.9	10	25.0	28.0	32.5
058301-VX	1-20	M20x1.5	15	1/2 3/4	15	11.5	14.0	48.0	12.5	13	27.0	30.0	32.5
058302-VX	2-25	M25x1.5	15	3/4 1	15/19	14.0	20.2	60.0	15.5	20	40.0	45.0	47.5
058303-VX	3-32	M32x1.5	15	1 1/4	19	20.0	26.5	76.0	21.7	40	45.0	51.0	55.0
058304-VX	4-40	M40x1.5	15	1 1/4 1 1/2	19/21	26.5	34.0	84.0	30.0	60	55.0	62.0	65.0
058355-VX	5s-50s	M50x1.5	15	1 1/2 2	21	32.5	38.0	90.0	36.3	80	70.0	79.0	82.5
058305-VX	5-50	M50x1.5	15	1 1/2 2	21	38.0	44.5	90.0	36.3	80	70.0	79.0	82.5
058365-VX	6s-63s	M63x1.5	15	2 2 1/2	21/30	44.5	50.0	96.0	47.9	100	85.0	96.0	97.5
058306-VX	6-63	M63x1.5	15	2 2 1/2	21/30	50.0	56.0	96.0	47.9	100	85.0	96.0	97.5
058307-VX	7-75	M75x1.5	15	2 1/2 3	30/32	56.0	65.0	105.0	58.2	120	96.0	108.0	115.5

All dimensions except NPT are in mm. Intermediate thread sizes are available on request. NPT threads should be tightened 'wrench tight'.

CCG reserves the right to make alterations to the technical data, dimensions, designs and products available without notice. The illustrations cannot be considered binding. Please contact CCG for assistance.

FLPTRVX-BG010622

FLP-TR (VORTEX[®]) BARRIER GLAND

ENCLOSURES AND EQUIPMENT TO WHICH CABLE GLANDS ARE FITTED:-

- Must be made from materials which are compatible with the cable gland materials.
- Have a sealing area around the cable gland entry point with a surface roughness <math>< Ra 6.3 \mu m</math>.
- Have entries that are perpendicular to the enclosure face in the area where the cable gland will seal to within 2.5°.
- Are sealed using the supplied sealing gasket (parallel threads) or by fully tightening into a threaded entry (tapered threads). Note that for tapered threads the IP rating can be improved to IP68 with the use of a suitable thread sealant.

MUST HAVE THREADED ENTRIES

- The same thread size as the cable gland. (Thread adapters should be used to correct

any mismatch).

- With a thread tolerance of metric class '6H' or equivalent.
- Where the thread length is a minimum of 10mm for Ex d applications or 3mm for all other applications

OR CLEARANCE HOLES (not Ex d)

- Where the hole size is the thread nominal size with a tolerance of +0.1 to +0.7mm. (e.g. the clearance hole for an M20 thread will have a diameter between 20.1mm and 20.7mm).
- Through material that is between 1mm and 12mm thick. (Thicker materials can be accommodated using glands with extended entry threads.)

1. Strip back the outer sheath to expose the inner cable cores. Using a clean cloth, clean the cable cores insulation.

If the cable cores have screens these should be cut away or twisted together into a single core. This single core should be insulated with heat shrink tubing or coated with insulating varnish. Any drain wires should also be insulated with heat shrink tubing or coated with insulating varnish.



2. Using insulation tape, bundle the cores together at the end.

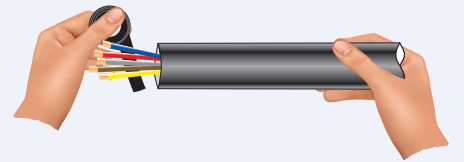

3. To maintain IP66/68, ensure the thread gasket ① is in place. Screw the gland unit into the apparatus and tighten the inner ② to the installation torque. Ensure the locknut ④ is screwed up against the inner ②. Pass the cable end through the outer ③ and push the bundled cable cores through the inner diaphragm and seal.

If the gland has NPT entry threads fitted to a threaded entry then IP68 (2m) can be achieved by applying one of the following tested and approved grease types to the thread:- Renolit Lubrene CA700 or LX220 EP2, Renolit LC-WP2 or Moly LX2, or Dow Corning 4 Electrical Compound.

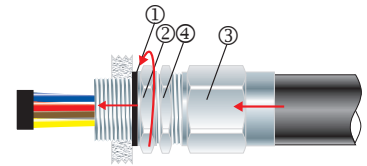

4. Unscrew the outer ③. Withdraw the cable and barrier pot sub-assembly ⑤. Remove the insulation tape.

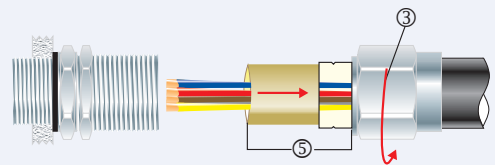

5. Remove the cap ⑧ from resin applicator and attach the mixing nozzle ⑨ (use extension nozzle for small multicore cables). Whilst holding the barrier pot sub-assembly ⑤ upright and holding the diaphragm seal firmly against the cable sheath inject the resin into the resin chamber*. Ensure the resin fills the inspectible resin seal pot ⑥ all the way to the top of the protective resin pot ⑦ and wipe any excess resin away.

Wait for the resin to set from a liquid to a gel, this should take:

- 15 minutes at 10°C
- 7 minutes at 20°C
- 6 minutes at 30°C
- 5 minutes at 40°C

For installations in less than 5°C Ambient, warm the Resin tube in warm water at ± 50°C. If there is still Resin left in the tube, discard the mixing nozzle ⑨ and replace the cap ⑧ for use with the next gland.

* The installation is acceptable if the cable sheath is pushed 2mm or 3mm into the resin seal.

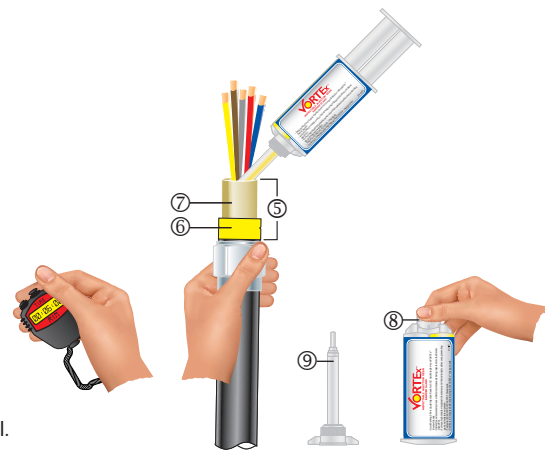

6. Re-insert the barrier pot sub-assembly ⑤ back into the inner ②.

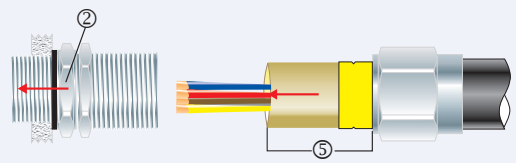

7. Tighten the outer ③ to the installation torque using a CCG Spanner ⑩ to produce a seal and grip on the cable. Tighten the locknut ④ up against the outer ③.

